

# ZOOMLION ROUGH TERRAIN CRANE ZRT1100D533



**ZOOMLION**

**Zoomlion Heavy Industry Science & Technology Co.,Ltd.**

Add: No.677, Lugu Road, Zoomlion Industrial Park, Changsha, Hunan, China, 410205

Copyright©2020 Zoomlion. All rights reserved. Reproduction and copying of any part of contents is not allowed for any purposes without Zoomlion's approval.



Product specifications are subject to change without notice and obligation. The photographs and/or drawing in this document are for illustrative purposes only. Please consult your local ZOOMLION dealer for more information.  
website:en.zoomlion.com 2020.12.09

**ZOOMLION**

**4.0**  
PRODUCTS



# CONTENTS

HIGHLIGHTS .....	2
DEMENSIONS .....	3
STEERING RADII .....	3
WEIGHTS .....	4
WORKING SPEEDS .....	4
LIFTING CAPACITY/RANGE DIAGRAM .....	4-14
TECHNICAL DESCRIPTION .....	15-17
TECHNICAL PARAMETER .....	18

## HIGHLIGHTS

### 1. Powerful performances

- The 49m main boom of super large U-shape cross section achieves stronger rated lifting capacity reaching 110t and better bearing capability; its comprehensive lifting capacity surpasses other competing products of the same tonnage level in the industry, thanks to its super-strong outriggers + lift-and-carry capability.
- Golden configuration of the power train: Cummins (US) engine + DANA (US) transmission + KESSLER (Germany) axles, four-wheel drive, four-wheel multi-mode steering, altogether achieves higher maximum driving speed and gradeability.

### 2. Superior reliability and durability

- Key parts and components adopt renowned brands at home or abroad. The crane has passed reliability tests conducted in regions such as plateaus, deserts, mountains and hills, etc., as well as tests done by Chinese and international institutes with issued ANSI and CE certificates.

### 3. High intelligence and safety

- The crane is configured with an intelligent device management platform which provides functions such as monitoring and control of crane operations and driving safety, fault diagnosis, and operational information recording, etc., and provides real-time reminding to the operator on safety, malfunction and maintenance.

### 4. Great comfort and beautiful contour

- Zoomlion's new generation of driver's cab is equipped with a push front window and a panoramic sunroof, providing better field of vision for the operator. The cab can be tilted backward, thus reducing operational fatigue. The 12-inch large display and spatial arrangements of instruments in an ergonomic way enhance the operator's operational comfort.
- The green and environment-friendly painting provides the crane with a fashion look and strong visual enjoyment from its expression of both beauty and strength.



# DEMENSIONS

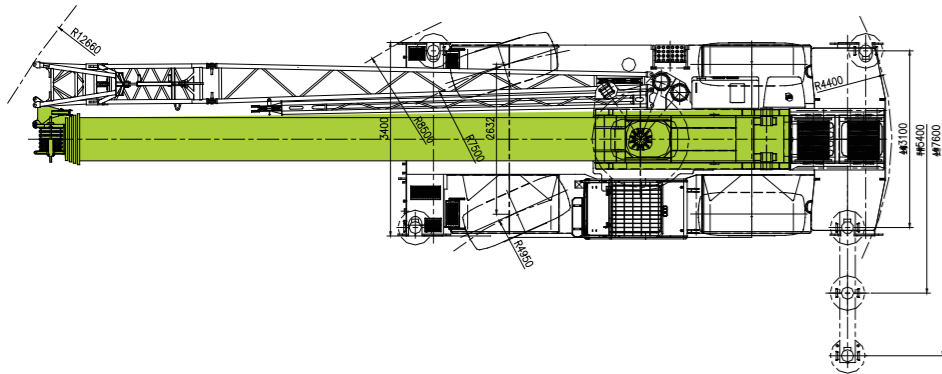
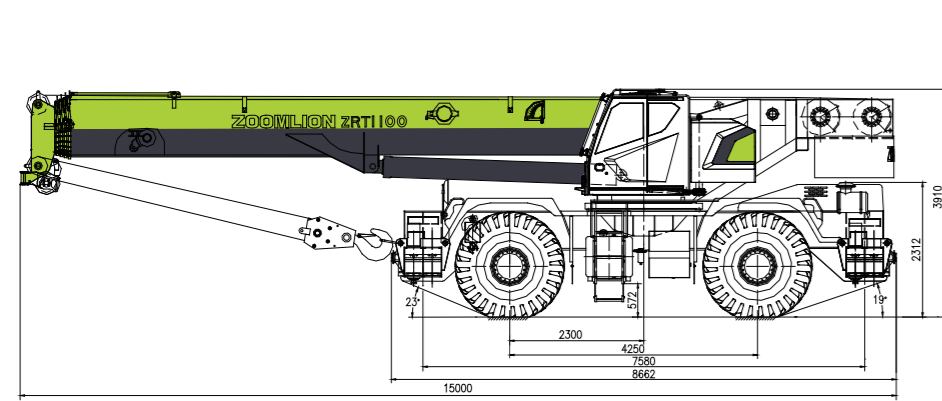

# STEERING RADII

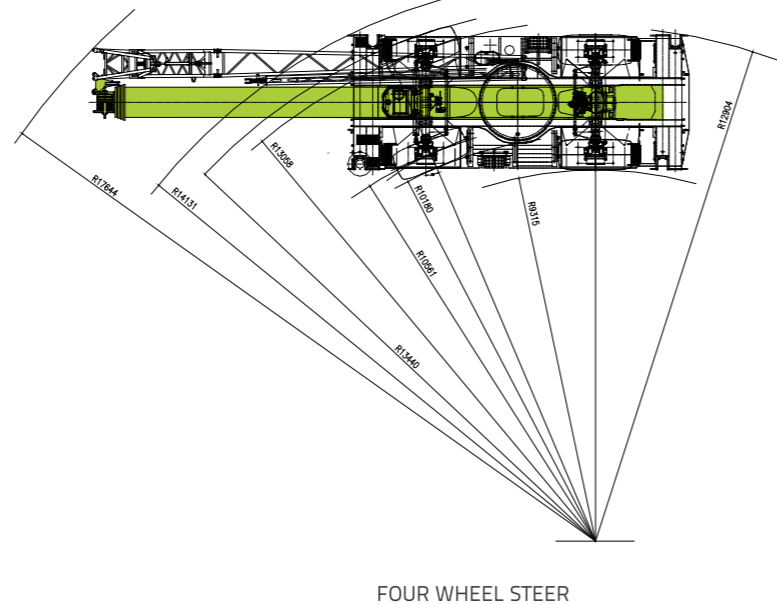
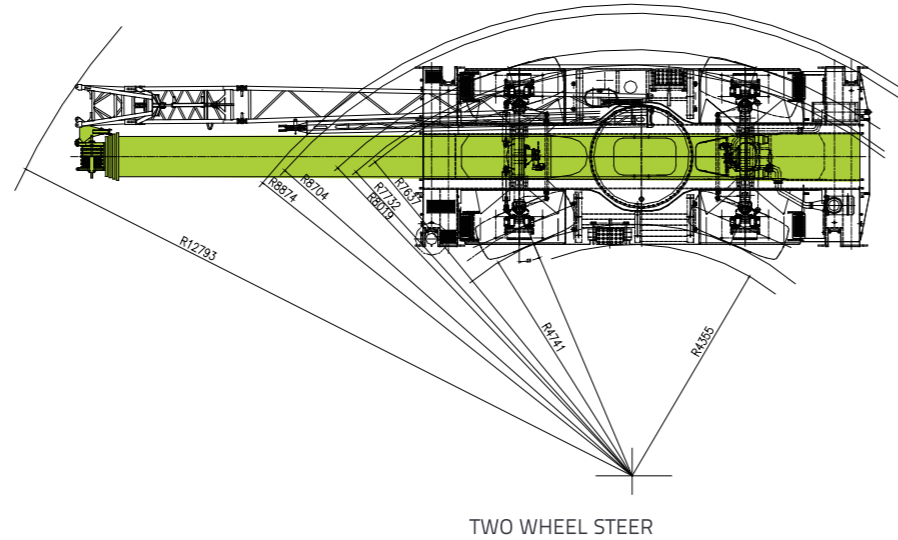

# WEIGHTS

## Hook block and hook ball

Rated load /t	Number of sheave	Reeving	Hook block weight/kg	Standard/Optional
85T	6	13	620	standard
6.5T	-	1	150	standard
110T	7	14	840	optional
35T	3	6	380	optional

## Axle load

Shaft	Front axle	Rear axle	Total weight
Axle load/t	29T	31T	60T
Note	With main and auxiliary hooks		

## Working speeds

	km/h min. MIN.	km/h max. MAX.	%	
29.5-25-34PR	0-1.6	35	96.7	6/R6

	Operation Speed	Rope diameter/length	Max. single line pull
	130m/min	Φ 20mm/260m	6500Kg
	130m/min	Φ 20mm/140m	6500Kg
	0 ~ 1.6r/min		
	Min.boom derricking up time 60s Min. boom derricking down time 90s		
	telescoping out/in time 135s		

# LIFTING CAPACITY TABLES

Rated Load on Outriggers Fully Extended



LOAD RADIUS (M)	Outriggers and telescoping cylinder fully extended, over sides and rear, 12.5 t counterweight								
	12.6	17.3	21.9	26.4	30.9	35.4	39.9	44.4	49
2.5	110000**								
3	100000**	66000							
3.5	85000*	66000	47000						
4	78000	66000	47000	38000					
4.5	72000	63000	47000	38000					
5	68000	58000	46000	38000	34000				
5.5	62500	53500	43500	38000	34000				
6	57500	49500	41000	37000	33000	30000			
7	48000	43000	38000	35200	30000	27500	21000		
8	38500	36500	34000	32000	27000	25500	21000		
9	29000	27000	28500	28500	25000	24000	20000	17500	
10		22500	22800	24600	22500	22500	19000	17000	13000
11		19500	18600	20200	18600	21200	18000	15800	13000
12		16000	15500	17800	16400	19000	16500	14600	12800
14			10800	12800	12500	13500	13800	13000	11800
16			8500	9800	9800	10000	11000	11000	10500
18				7500	7800	8600	9000	9600	9600
20				5800	6400	7000	7300	7800	8000
22					4800	5800	6200	6200	6700
24					4000	4700	4900	5200	5500
26						3700	4000	4400	4800
28						3000	3300	3700	3800
30							2600	3000	3200
32							2100	2500	2700
34								2100	2300
36									1700
38									1500
40									1200
42									1000
I (m)	0	4.7	9.3	9.3	9.3	9.3	9.3	9.3	9.3
II (m)	0	0	0	4.5	9	13.5	18	22.5	27.1
Reeving	12	12	8	8	6	6	4	4	4
Hook	85t								

Noted: The operating modes marked with \* in this Table are ones which need using a removable pulley block and selecting a reeving factor of 13 when the crane is working over sides or rear working area. For ones marked with \*\*, a reeving factor of 14 should be selected, and a 110 t hook should be used with an additional special device.

# LIFTING CAPACITY TABLES

Rated Load on Outriggers Fully Extended



LOAD RADIUS (M)	Outriggers fully extended and telescoping cylinder I intermediately extended, over sides and rear, 12,5 t counterweight							
	12,6	17,3	21,8	26,3	30,8	35,3	39,8	44,4
2,5	110000							
3	100000	66000						
3,5	85000	66000	38000					
4	78000	66000	38000	34000				
4,5	72000	63000	38000	34000				
5	68000	58000	38000	34000	30000			
5,5	62500	53500	37000	34000	30000			
6	57500	49500	36000	32000	30000	24000		
7	48000	43000	34000	31000	29000	23000		
8	38500	36500	32000	30500	27000	22000	18000	
9	29000	27000	28000	29000	26000	20000	18000	13500
10		22500	24500	25500	24500	18400	16400	13500
11		19500	20500	21500	22500	16800	15000	13000
12		16000	17500	18200	18800	15500	14000	12600
14			12400	12800	13500	13400	12100	10800
16			9500	10400	11000	11800	10600	9500
18				8400	8500	8800	9500	8500
20					6500	7000	7400	7700
22						5800	6000	7000
24							4800	5800
26								4200
28								3200
30								2800
32								2500
34								2400
36								1800
38								1200
40								
42								
I(m)	0	4,7	4,7	4,7	4,7	4,7	4,7	4,7
II(m)	0	0	4,5	9	13,5	18	22,5	27,1
Reeving	12	12	8	8	6	6	4	4
Hook								85t

Rated Load on Outriggers Fully Extended



LOAD RADIUS (M)	Outriggers fully extended and telescoping cylinder I fully retracted, over sides and rear, 12,5 t counterweight							
	12,6	17,1	21,6	26,1	30,6	35,1	39,7	
2,5	110000							
3	100000	38000						
3,5	85000	38000	34000					
4	78000	38000	34000	30000				
4,5	72000	38000	34000	30000				
5	68000	38000	34000	30000	25000			
5,5	62500	37000	34000	29000	25000			
6	57500	36000	32000	28000	24000	19000		
7	48000	34000	31000	26000	22500	19000		
8	38500	32000	29000	24500	21000	18000	15000	
9	29000	30000	27000	23000	18800	17000	15000	
10		26000	25500	22000	17000	15400	13800	
11		22000	22000	20500	15800	14100	12800	
12		18400	18800	20000	14500	13000	11800	
14			14200	15000	12800	11200	10200	
16				11000	11500	11200	9800	
18					9500	10000	8800	
20						8000	8300	
22							7000	
24								
26								
28								
30								
32								
34								
36								
38								
40								
42								
I(m)	0	0	0	0	0	0	0	
II(m)	0	4,5	9	13,5	18	22,5	27,1	
Reeving	12	10	8	8	6	6	4	
Hook							85t	

# RANGE DIAGRAM

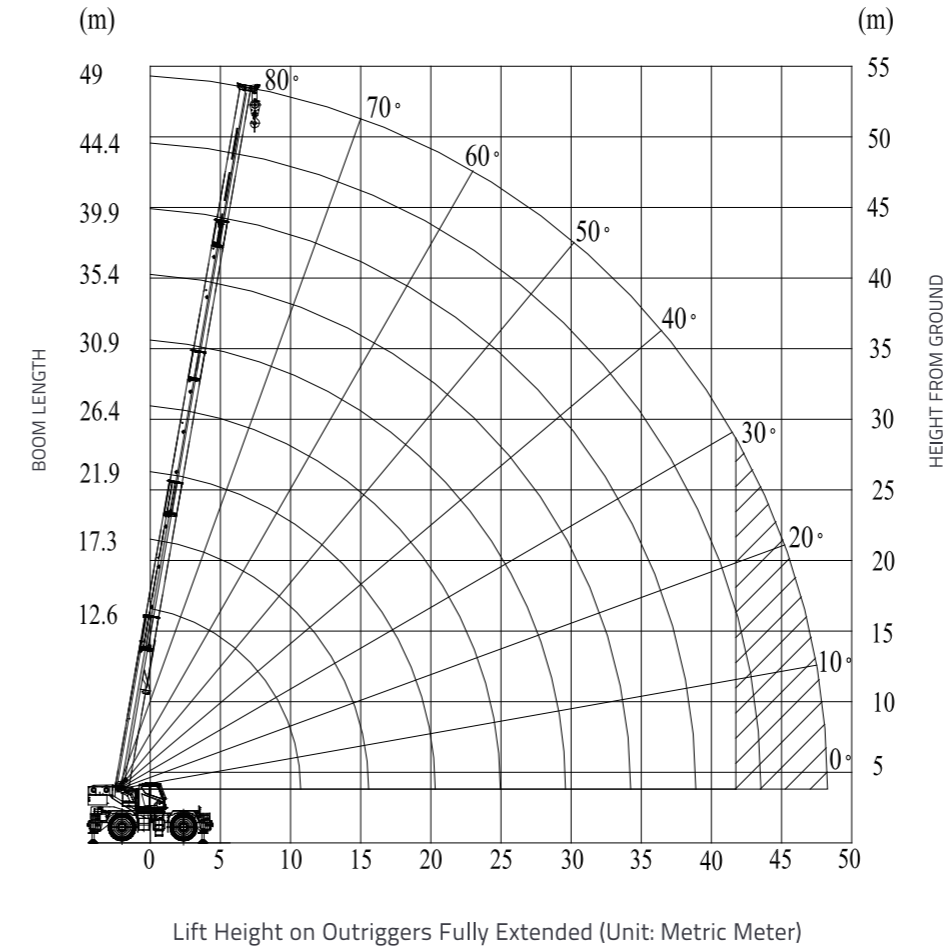

# LIFTING CAPACITY TABLES

Rated Load on Outriggers Fully Extended



BOOM ANGLE (°)	Outriggers fully extended, over sides and rear, 12,5 t counterweight		
	0°	15°	30°
80	6500	4600	4300
78	6300	4400	4200
76	6000	4300	3800
74	5600	4100	3600
72	5200	4000	3500
70	5000	3900	3400
68	4600	3800	3300
66	4500	3500	3300
64	4000	3200	3000
62	3200	2800	2600
60	2700	2500	2400
58	2400	2200	2100
56	2200	2000	1800
54	1900	1600	1500
52	1600	1400	1300
50	1400	1200	1100
48	1200	1100	1000
46	1100	1000	900
44	1000	900	
42	900		
40			
Reeving		1	
Hook		6.5t	

## RANGE DIAGRAM

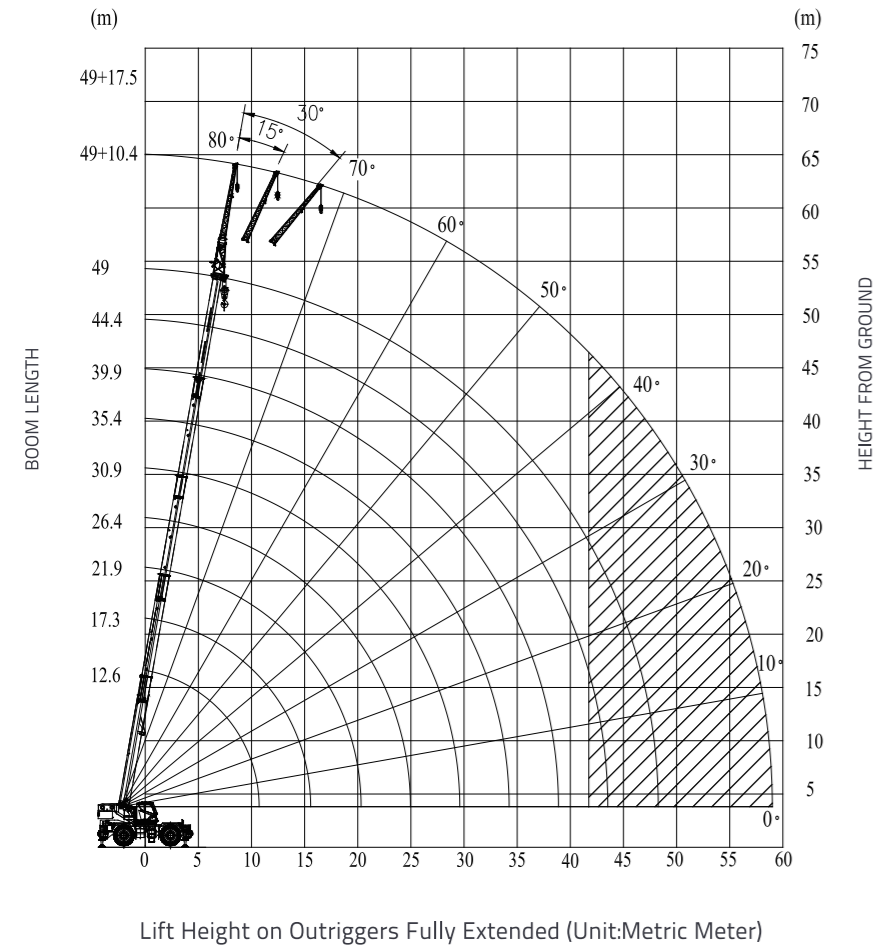

## LIFTING CAPACITY TABLES

Rated Load on Outriggers Fully Extended



MAIN BOOM + 17.5 M JIB

360°  
(UNIT: KG)



OUTRIGGERS FULLY EXTENDED

BOOM ANGLE (°)	Outriggers fully extended, over sides and rear, 12.5 t counterweight		
	0°	15°	30°
80	4000	2200	1800
78	3700	2000	1600
76	3300	1900	1500
74	3000	1800	1500
72	2900	1800	1500
70	2800	1800	1400
68	2700	1700	1400
66	2700	1700	1350
64	2600	1700	1350
62	2400	1600	1300
60	2200	1600	1300
58	1800	1600	1300
56	1500	1400	1300
54	1400	1300	1200
52	1200	1100	1100
50	1100	1000	1000
48	1000	900	900
46			
44			
42			
40			
Reeving	1		
Hook	6.5t		

## RANGE DIAGRAM

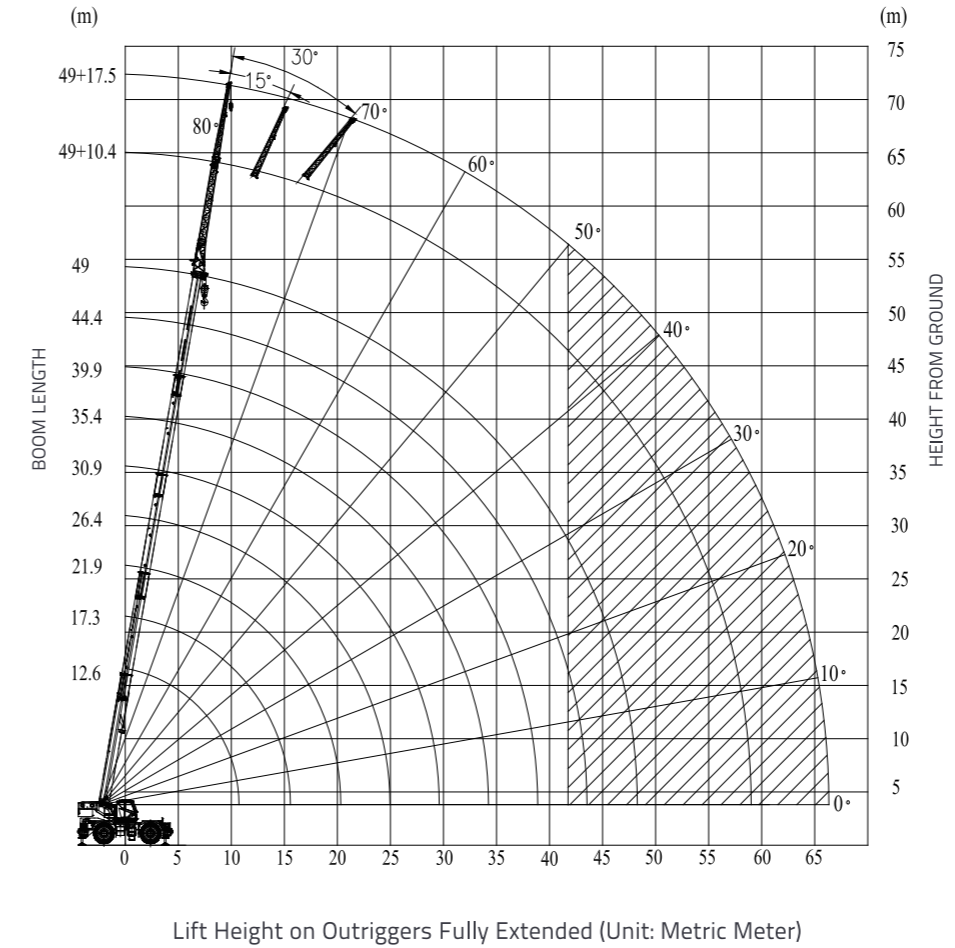

# LIFTING CAPACITY TABLES

Rated Load on Outriggers Pinned at Mid-Position



LOAD RADIUS (M)	Outriggers intermediately extended and telescoping cylinder I fully extended, over sides and rear, 12.5 t counterweight								
	12,6	17,3	21,9	26,4	30,9	35,4	39,9	44,4	49
2,5	110000								
3	100000	66000							
3,5	85000	66000	47000						
4	78000	66000	47000	38000					
4,5	72000	63000	47000	38000					
5	58000	55000	46000	38000	34000				
5,5	46000	46500	42000	38000	34000				
6	37000	37000	38500	37000	33000	30000			
7	26000	27000	28000	28500	30000	27500	21000		
8	20000	21000	20500	21500	22000	24000	21000		
9	16000	16000	16200	17000	17400	18000	20000	17500	
10		13000	13000	13800	14200	15000	15500	17000	13000
11		10000	10400	11000	11600	12400	13000	14000	13000
12		8400	8600	9200	9800	10000	10500	11000	11800
14			6000	6400	6800	7400	7800	8400	8600
16			4000	4500	4800	5400	5800	6500	6800
18				3500	3800	4200	4500	4800	5000
20				2600	3000	3200	3400	3600	4000
22					2200	2400	2800	3000	3200
24					1600	1800	2100	2400	2600
26						1400	1600	1800	2000
28						1000	1300	1500	1600
30							1000	1100	1300
32								1000	1100
34									
36									
38									
40									
42									
I	0	4,7	9,3	9,3	9,3	9,3	9,3	9,3	9,3
II	0	0	0	4,5	9	13,5	18	22,5	27,1
Reeving	12	12	8	8	6	4	4	4	4
Hook	85t								

Rated Load on Outriggers Pinned at Mid-Position



LOAD RADIUS (M)	Outriggers and telescoping cylinder I intermediately extended, over sides and rear, 12.5 t counterweight								
	12,6	17,3	21,8	26,3	30,8	35,3	39,8	44,4	
2,5	110000								
3	100000	66000							
3,5	85000	66000	38000						
4	78000	66000	38000	34000					
4,5	72000	63000	38000	34000					
5	58000	55000	38000	34000	30000				
5,5	46000	46500	37000	34000	30000				
6	37000	37000	33500	32000	30000	24000			
7	26000	27000	27500	30000	29000	23000			
8	20000	21000	22000	23000	24000	22000	18000		
9	16000	16000	16500	17200	18000	20000	18000	13500	
10		13000	13800	14500	15000	15500	16400	13500	
11		10000	11000	12000	12500	13000	15000	13000	
12		8400	9500	10000	10800	11000	11600	12600	
14			7000	7600	8000	8400	8800	10800	
16			5200	5600	6000	6400	6600	6800	
18				4500	4800	5200	5400	5500	
20				3200	3600	4000	4200	4200	
22					2800	3000	3400	3500	
24					2200	2400	2600	2800	
26						2000	2100	2200	
28						1500	1700	1800	
30							1400	1500	
32							1000	1200	
34								1000	
36									
38									
40									
42									
I	0	4,7	4,7	4,7	4,7	4,7	4,7	4,7	4,7
II	0	0	4,5	9	13,5	18	22,5	27,1	
Reeving	12	12	8	8	6	6	4	4	
Hook	85t								

# LIFTING CAPACITY TABLES

Rated Load on Outriggers Pinned at Mid-Position



LOAD RADIUS (M)	Outriggers intermediately extended and telescoping cylinder I fully retracted, over sides and rear, 12.5 t counterweight						
	12,6	17,1	21,6	26,1	30,6	35,1	39,7
2,5	110000						
3	100000	38000					
3,5	85000	38000	34000				
4	78000	38000	34000	30000			
4,5	72000	38000	34000	30000			
5	58000	38000	34000	30000	25000		
5,5	46000	37000	34000	29000	25000		
6	37000	36000	32000	28000	24000	19000	
7	26000	28000	30000	26000	22500	19000	
8	20000	23000	24000	24500	21000	18000	15000
9	16000	17500	18000	20000	18800	17000	15000
10		14000	15000	16400	17000	15400	13800
11		12000	13000	14000	15500	14100	12800
12		9500	10000	11000	12000	13000	11800
14			8000	8800	8800	9500	10200
16			6500	7000	7200	7400	8000
18				5600	5600	5800	6000
20				4500	4500	4800	5000
22					3700	4000	4200
24					3000	3200	3400
26						2800	2800
28						2200	2400
30							2000
32							1500
34							
36							
38							
40							
42							
I	0	0	0	0	0	0	0
II	0	4,5	9	13,5	18	22,5	27,1
Reeving	12	10	8	8	6	6	4
Hook	85t						

# RANGE DIAGRAM

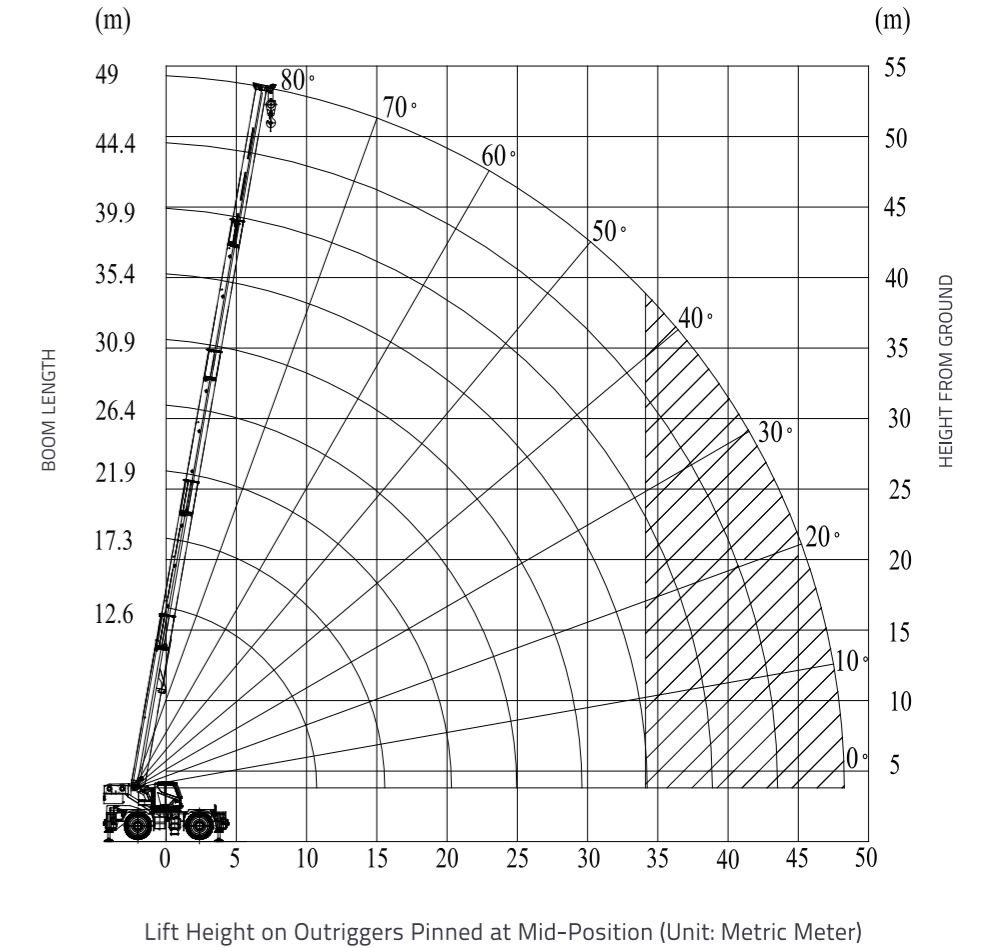

# LIFTING CAPACITY TABLES

Rated Load on Outriggers Fully Retracted



LOAD RADIUS (M)	Outriggers fully retracted and telescoping cylinder I fully extended, over sides and rear, 12.5 t counterweight									
	12,6	17,3	21,9	26,4	30,9	35,4	39,9	44,4	49	
2,5										
3	58000	55000								
3,5	45000	42000	42000							
4	36000	34000	32000	32000						
4,5	27000	27000	26000	26000						
5	23000	23500	22000	22500	24000					
5,5	18000	19000	18500	18800	19000					
6	16000	16800	16200	16500	17000	18000				
7	12000	12500	11800	12000	12000	13000	14000			
8	9500	9200	8800	9000	8200	9000	10000			
9	7500	7000	6800	7200	7500	8000	8500	10000		
10		5600	5200	5500	6000	6500	6800	7500	8000	
11		4200	4200	4500	5000	5200	5500	6000	6200	
12		3000	3000	3200	3500	4000	4500	5000	5200	
14			1800	2200	2500	3000	3200	3500	3600	
16			1000	1200	1500	1800	2100	2300	2500	
18				1000	1100	1200	1500	1700	1800	
20						1000	1200	1300	1400	
22							1000	1000	1100	
24									900	
26										
28										
30										
32										
34										
36										
38										
40										
42										
I(m)	0	4,7	9,3	9,3	9,3	9,3	9,3	9,3	9,3	9,3
II(m)	0	0	0	4,5	9	13,5	18	22,5	27,1	
Reeving	12	10	8	8	6	4	4	4	4	
Hook										85t

Rated Load on Outriggers Pinned at Mid-Position



LOAD RADIUS (M)	Outriggers fully retracted and telescoping cylinder I intermediately extended, over sides and rear, 12.5 t counterweight									
	12,6	17,3	21,8	26,3	30,8	35,3	39,8	44,4		
2,5										
3	58000	55000								
3,5	45000	42000	38000							
4	36000	34000	34000	34000						
4,5	27000	27000	28000	28000						
5	23000	23500	24000	24000	25000					
5,5	18000	19000	18800	19000	20000					
6	16000	16800	17000	17000	17500	18000				
7	12000	12500	13000	13500	14000	14400				
8	9500	9200	9500	10000	10800	11500	12000			
9	7500	7000	7500	8000	8500	9000	9200	10000		
10		5600	6200	6500	7200	7800	8000	8400		
11		4200	5000	5500	6000	6500	6800	7000		
12		3000	3600	4000	4800	5200	5600	6000		
14			2400	2800	3200	3600	4000	4300		
16			1800	2000	2400	2800	3000	3000		
18				1600	1800	2000	2200	2400		
20				1000	1200	1500	1600	1700		
22					1000	1100	1200	1300		
24							1000	1000		
26										
28										
30										
32										
34										
36										
38										
40										
42										
I(m)	0	4,7	4,7	4,7	4,7	4,7	4,7	4,7	4,7	
II(m)	0	0	4,5	9	13,5	18	22,5	27,1		
Reeving	12	10	8	8	6	6	4	4		
Hook										85t

# LIFTING CAPACITY TABLES

Rated Load on Outriggers Fully Retracted



LOAD RADIUS (M)	Outriggers intermediately extended and telescoping cylinder I fully retracted, over sides and rear, 12.5 t counterweight							
	12,6	17,1	21,6	26,1	30,6	35,1	39,7	
2,5	58000							
3	45000	38000						
3,5	36000	38000	34000					
4	27000	34000	34000	30000				
4,5	23000	28000	29000	30000				
5	18000	22000	23000	24000	25000			
5,5	16000	20000	21000	21500	23000			
6	12000	16000	17000	17800	18000	19000		
7	9500	12500	13000	13500	14000	14500		
8	7500	10000	10800	11000	11800	12000	12500	
9		8400	9000	9500	9800	10000	10000	
10		7000	7800	8000	8000	8400	8800	
11		5800	6200	6800	7000	7200	7500	
12		4500	4800	5400	5800	6000	6400	
14			3200	3800	4000	4200	4600	
16			2600	3000	3200	3200	3200	
18				2200	2400	2600	2600	
20					1600	1800	2100	2200
22						1400	1500	1600
24							1100	1200
26							1000	1100
28								900
30								
32								
34								
36								
38								
40								
42								
I(m)	0	0	0	0	0	0	0	0
II(m)	0	4,5	9	13,5	18	22,5	27,1	
Reeving	12	10	8	8	6	6	4	
Hook								85t

# RANGE DIAGRAM

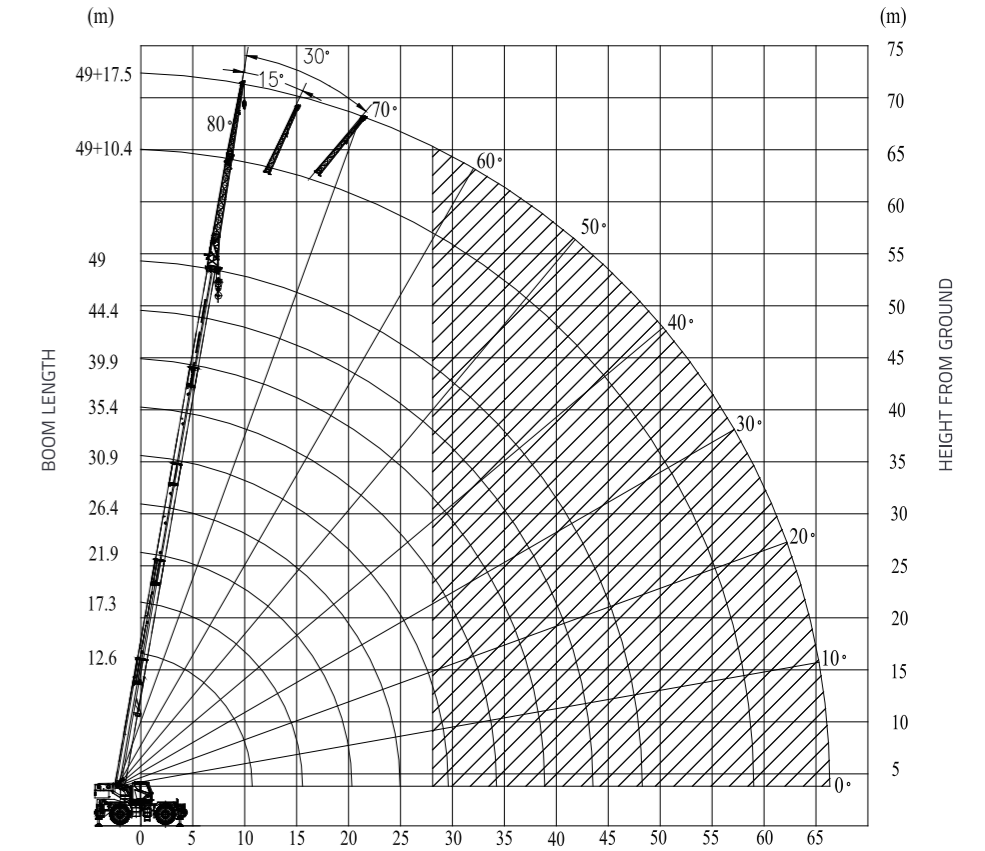

Lift Height on Outriggers Fully Retracted (Unit: Metric Meter)

# LIFTING CAPACITY TABLES

Rated Load on Tires

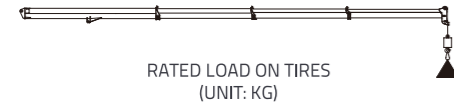

LOAD RADIUS (M)	Cylinder I fully retracted, on tires, 360-degree working area, with 12.5t counterweight			
	12.6	17.1	21.6	26.1
3	21000	20000		
3.5	18000	17500		
4	16000	15200	16500	14200
4.5	13800	13000	14000	12000
5	11000	11000	11500	10200
5.5	9800	9500	9800	9200
6	8500	8000	8800	8300
7	6200	6200	7000	7200
8	4500	4800	5400	6000
9	3200	3400	4000	4500
10		2800	3200	3600
11		2200	2500	3000
12		1800	2000	2600
14			1700	2000
16			1300	1600
18				1200
20				1000
22				
l(m)	0	0	0	0
ll(m)	0	4.5	9	13.5
Reeving	12	10	8	8
Hook	85t			

Rated Load on Tires

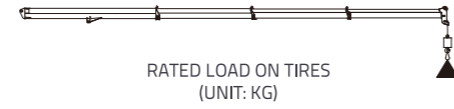

LOAD RADIUS (M)	Cylinder I fully retracted, on tires, over front working area, with 12.5t counterweight			
	12.6	17.1	21.6	26.1
3	30000	28000		
3.5	27000	26000		
4	24000	23500	23000	22000
4.5	21000	21000	21000	20000
5	20000	19500	19000	18000
5.5	17000	17800	16500	16000
6	15000	16000	15000	14500
7	11500	13500	12500	12500
8	8800	10500	10000	9800
9	6200	8800	8500	8400
10		7200	7400	7200
11		5800	6000	6200
12		4500	4800	5000
14			3600	3800
16			2800	3000
18				2200
20				1600
22				
l(m)	0	0	0	0
ll(m)	0	4.5	9	13.5
Reeving	12	10	8	8
Hook	85t			

# LIFTING CAPACITY TABLES

Rated Load on Tires

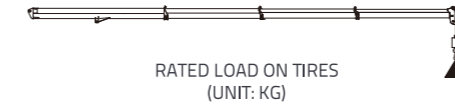

LOAD RADIUS (M)	Cylinder I fully retracted, lift and carry, over front working area, with 12.5t counterweight			
	12.6	17.1	21.6	26.1
3	19500	19000		
3.5	17000	16800		
4	15500	15200	15000	14500
4.5	13500	13500	13500	13000
5	12000	12000	12200	11500
5.5	10800	10500	11000	10000
6	9800	9600	9800	8800
7	8000	8500	8400	7500
8	6600	7200	7200	6500
9	4500	5000	6500	5500
10		4400	5400	4600
11		3600	4300	3600
12		2800	3200	2800
14			2200	2200
16			1600	1700
18				1400
20				1000
22				
l(m)	0	0	0	0
ll(m)	0	4.5	9	13.5
Reeving	12	10	9	8
Hook	85t			

# RANGE DIAGRAM

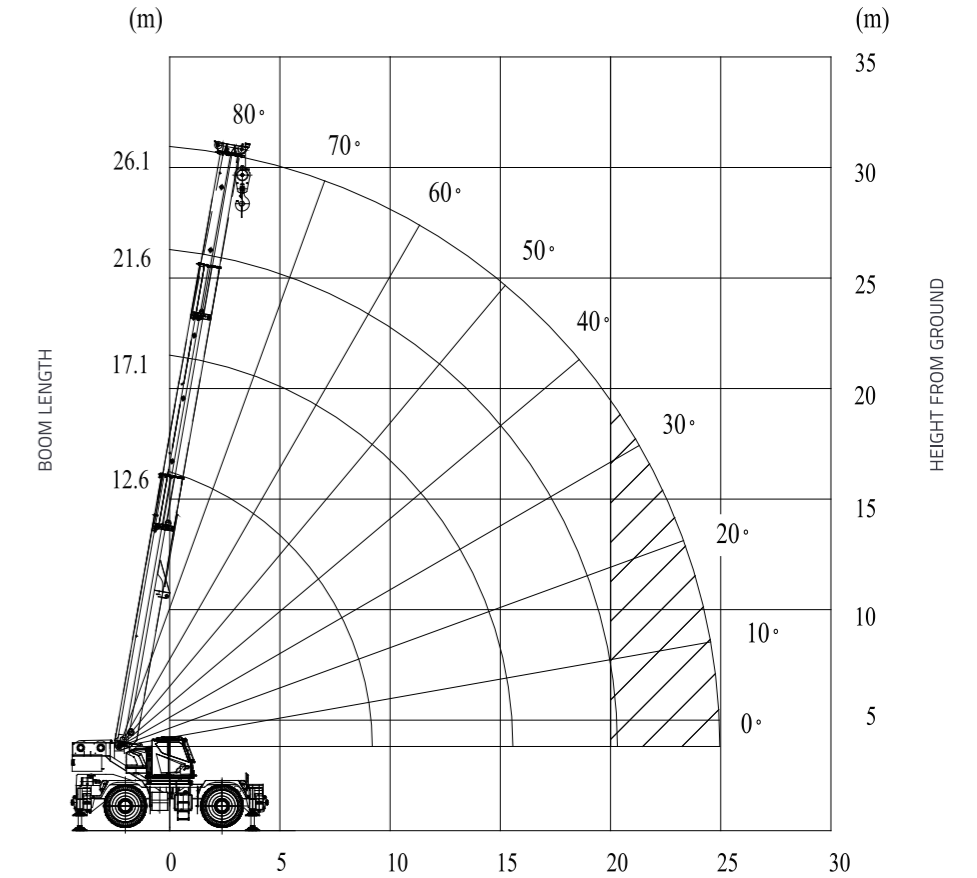



## TECHNICAL DESCRIPTION



### Engine

Engine type---- CUMMINS QSB6.7  
Rated power--- 194 KW / 2400 RPM  
Maximum output torque---990 Nm / 1500 RPM  
Oil tank capacity-----300L  
Exhaust emissions: Non-road Emission Standard III



### MAIN BOOM

The box-shaped main boom consists of 5 U-type boom sections made of high-strength steel.  
The main boom head is equipped with 6 sheaves, which is convenient for changing reeving factors without removing the wedges. The rooster sheave and a dismountable pulley block are included in the standard configuration.  
Min. main boom length (with telescopic sections completely retracted): 12600 mm  
Max. main boom length (with telescopic sections completely extended): 49000 mm  
Min. telescoping out time ----- 135 s  
Derrick angle and speed ----- 1° - 80° / 60 s



### MAX. BOOM LENGTH WITH JIB EXTENSION

It consists of two jib sections of lattice structure. The jib section II is secured into the jib section I, and can be extended outward from one side of the section I. The whole jib is side stowed with the main boom via moveable pins during driving.  
A sheave is assembled at the jib head.  
Offset ----- 0°, 15° and 30°  
Jib length ----- 10.4m – 17.5 m



### MAIN AND AUXILIARY WINCHES

The main and auxiliary winches are equipped with the same spare parts. An axial variable-displacement hydraulic motor drives the drum to rotate through a planetary reducer, so as to lift and lower a load.  
Max. hoist rope strength ----- 6500 kg  
Max. hoist rope speed ----- 130 m/min (At the 4th layer)  
Rope diameter -----  $\Phi$  20 mm  
Main winch rope length ----- 260 m  
Auxiliary winch rope length ----- 140 m

## TECHNICAL DESCRIPTION



### MAIN AND AUXILIARY WINCHES

Rotatable main hook: 85 t, with 6 sheaves and hook latch, secured at the chassis frame in front of the slewing table.  
Rotatable auxiliary hook: 6.5 ton, with hook latch, used with the rooster sheave and jib, secured at the auxiliary hook holder on the chassis frame.  
Rotatable hook: 110 t (optional), with 7 sheaves and a hook latch, secured at the chassis frame in front of the slewing table.



### SWING

It consists of a hydraulic motor, two planetary gear reducers, a pinion gear and a swing bearing, etc. Via the planetary gear reducer, the hydraulic motor drives the pinion gear to rotate and makes the swing bearing outer ring rotate around its inner toothed ring fixed on chassis frame, providing superstructure with 360° unlimited swing.  
Hydraulically controlled usually-closed brake, capable of free swing function, and installed with a pneumatic swing lockout device.  
Swing speed ----- 0 – 1.6 r/min



### HYDRAULIC SYSTEM

The dual variable plunger pumps mounted on the PTO supply oil to the telescoping, derricking and hoist mechanisms.  
A gear pump installed at the PTO supplies oil to the slewing and steering mechanisms.  
Another gear pump mounted on the engine supplies oil to the outriggers, braking system, oil radiator of the torque converter and air conditioner.  
Hydraulic oil tank capacity ----- 1100 L



### OPERATOR CAB

The cab is side-mounted and adopts left-hand drive. A single seat is installed inside the cab.  
A hydraulic steering gear (manufacturer: EATON Ji'ning) and an air conditioner for both heating and cooling (manufacturer: Yuxin He'nan) are installed in the crane.  
Emission complies with the requirements of Europe environment protection standards.  
There are two control boxes on the both sides of operator's seat. The left / right control box can be pulled up. The controls of the superstructure are arranged according to the requirements of ASME B30.5-2007 standard and comply with ISO (International Organization for Standardization) standard.  
Length ----- 1810 ± 5 mm  
Width ----- 1050 ± 5 mm  
Height ----- 1710 ± 5 mm

## TECHNICAL DESCRIPTION

### OUTRIGGER SYSTEM

4 H-type outriggers, hydraulically controlled, can be operated in the cab simultaneously or independently.

Each vertical jack cylinder is equipped with a two-way hydraulic lock to ensure that outriggers are secured reliably during working or driving.

Outrigger boxes are directly welded onto the chassis frame.

The outriggers can be completely extended, intermediately extended or completely retracted for different crane operations.

Outrigger spread (Height): 7580 mm

Outrigger spread (Width): 7600 mm (fully extended)

5400 mm (half extended)

3100 mm (fully retracted)

### AXLES

Front axle :A rigidly connected steering and driving axle, installed with a planetary reducer and a brake.

Rear axle:A full-floating steering and driving axle, installed with a planetary reducer and a brake.

### STEERING

Fully-hydraulic power steering gear, The cylinder of steering and driving axle is controlled by the steering wheel to realize crane steering.

4 steering modes:

2-wheel steering – front wheel steering

2-wheel steering – rear wheel steering

4-wheel steering – all-wheel steering

4-wheel steering – crab steering

### BRAKES

Service brake Hydraulically controlled disc brake on 4 wheels

Parking brake Hydraulically released parking brake, under the action of the spring mounted on the input shaft of front axle.

### ELECTRIC SYSTEM

24 Volt DC

2 batteries with 12 V rated voltage and 120 Ah rated current

### SAFETY DEVICE

Rated capacity indicator (RCI)

Hydraulic safety valve

Rotating beacon and horn

Swing brake

Hoisting limit switch

Swing lockout device

Lower limit switch

Boom angle indicator

Balance valve

Outrigger beam retaining pin

Hydraulic lock

Emergency stop button

### SUSPENSION SYSTEM

Front axle: rigidly mounted to the chassis frame

Rear axle: oscillation axle, connecting to chassis frame via a hydraulic suspension cylinder

### COUNTERWEIGHT

Counterweight :12500kg(27500lbs)

Length..... 3200mm

width.....1300mm

Height..... 785mm

## TECHNICAL PARAMETERS

Type	Item	Value	
Working performance	Max. rated lifting capacity × working radius	kg.m	110000×2.5
	Max. load moment of main boom	kN.m	3381
	Max. load moment of main boom (fully extended)	kN.m	1693
	Max. lifting height of main boom (fully extended)	m	49.2 (from the lower end of hook to ground, i.e. from 2.5 m below the boom top point to the ground)
	Max. lifting height of jib	m	66.8 (from the lower end of hook to ground, i.e. from 2.5 m below the boom top point to the ground)
Dimensions	Overall dimensions (L × W × H)	mm	15000×3400×3910
	Outrigger spread(Height × Width)	mm	7580×7600
	Main boom length	mm	12600 - 49000
	Jib length	mm	10400 - 17500
	Boom angle	°	-1 - 80
	Swing range		360° unlimited swing (Full range)
Working speeds	Max. hoist rope speed (Main winch)	m/min	130
	Min. boom telescoping out time	s	135
	Min. boom telescoping in time	s	135
	Min. boom derricking up time	s	60
	Min. boom derricking down time	s	≤90
	Swing speed	r/min	0-1.6
Hydraulic system	Maximum working pressure	MPa	31
	Rate working flow	L/min	280
	Hydraulic oil tank capacity	L	1100
Gross vehicle mass	Gross weight	kg	60000
	Front weight	kg	29000
	Rear weight	kg	31000
Driving	Highest driving speed (forward/backward)	km/h	35/35
	Wheelbase	mm	4250
	Treads(Front / Rear)	mm	2632
	Max. gradeability	%	96.7